

Ball Screw Support 滚珠丝杠支撑座

BK Series Fixed Side Rectangular Type



Assembly consists of:

Item No.	Part Name	Quantity
1	Housing	1
2	Bearing	1 set
3	Holding Lid	1
4	Collar	2
5	Seal	1 (2)
6	Lock Nut	1
7	Hexagon Socket Head Setscrew (with set piece)	1

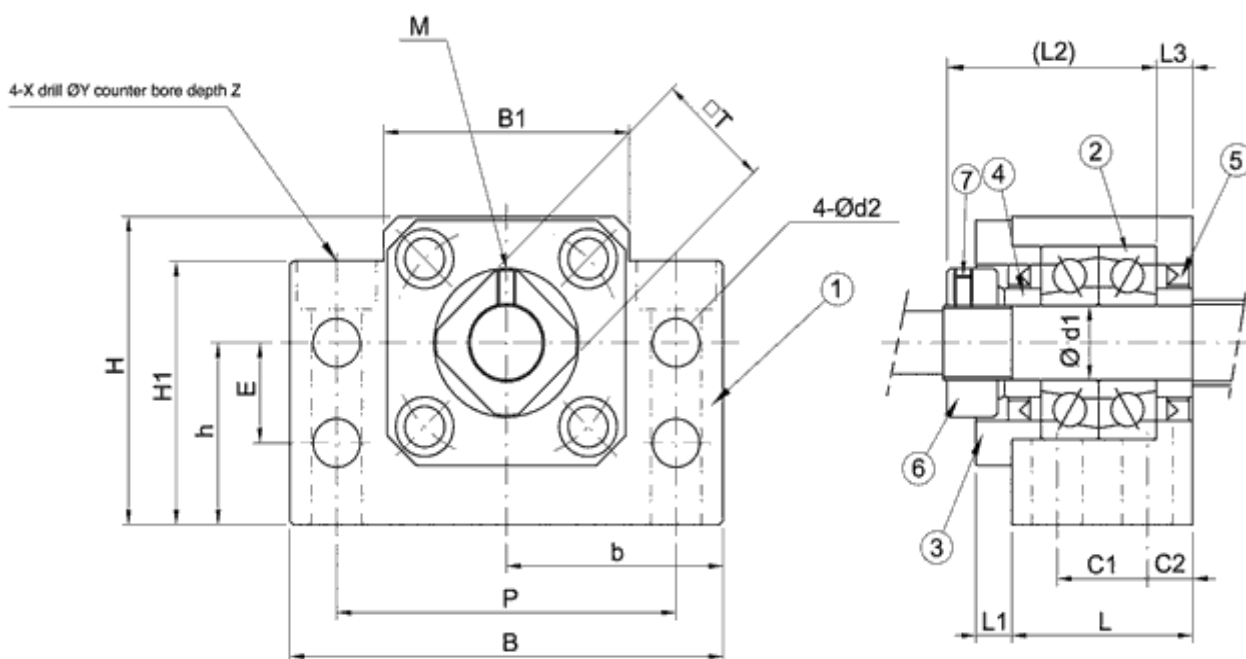
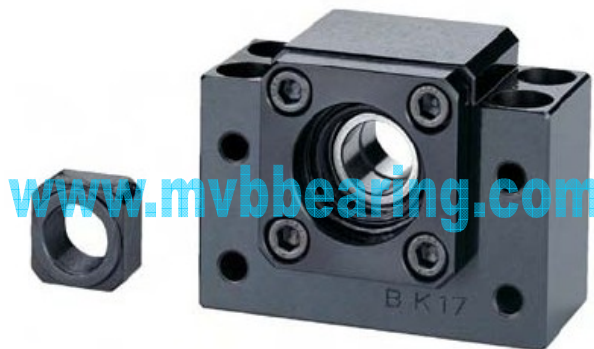

All Dimensions in mm

Part Number	d1	L	L1	L2	L3	B	H	b	h	B1	H1	E	P	C1	C2	d2	X	Y	Z	M	T
								±0.02	±0.02												
BK10	10	25	5	29	5	60	39	30	22	34	32.5	15	46	13	6	5.5	6.6	10.8	5	M3	16
BK12	12	25	5	29	5	60	43	30	25	35	32.5	18	46	13	6	5.5	6.6	10.8	1.5	M3	19
BK15	15	27	6	32	6	70	48	35	28	40	38	18	54	15	6	5.5	6.6	11	6.5	M3	22
BK17	17	35	9	44	7	86	64	43	39	50	55	28	68	19	8	6.6	9	14	8.5	M4	24
BK20	20	35	8	43	8	88	60	44	34	52	50	22	70	19	8	6.6	9	14	8.5	M4	30
BK25	25	42	12	54	9	106	80	53	48	64	70	33	85	22	10	9	11	17.5	11	M5	35
BK30	30	45	14	61	9	128	89	64	51	76	78	33	102	23	11	11	14	20	13	M6	40
BK35	35	50	14	67	12	140	96	70	52	88	79	35	114	26	12	11	14	20	13	M8	50
BK40	40	61	18	76	15	160	110	80	60	100	90	37	130	33	14	14	18	26	17.5	M8	50

Features

- Do not disassemble the support unit
- The bearing is filled with grease
- When inserting a screw shaft into the support unit, take care to prevent peeling the oil-seal lip
- After inserting the fixed side support unit, lock the lock nut using the set piece and hexagon socket head setscrew

MVB Power-Star Bearing Industry Co., Ltd.

Tel: +86-592-523 0986 Fax: +86-592-376 1975

Url: www.mvbbearing.com

Email: vivy@mvbbearing.com ; mvbbearing@gmail.com